

SINEWAVE INVERTER



SAMLEX EUROPE[®] B.V.

Pure Sinewave Inverter

Model No.

PS300-12

PS350-24

PS450-48

PS600-12

PS800-24

PS800-48

Manual, Gebruiksaanwijzing, Bedienungsanleitung,
Mode D'Emploi, Manual del propietario

Please read this manual before operating your inverter

Powersine PS300-800 inverter owner's manual © 2004-2015 Samlex Europe B.V.. All rights reserved. No part of this document may be reproduced in any form or disclosed to third parties without the express written permission of Samlex Europe B.V., Aris van Broekweg 15, 1507 BA, Zaandam, The Netherlands. Samlex Europe B.V. reserves the right to revise this document and to periodically make changes to the content hereof without obligation or organization of such revisions or changes, unless required to do so by prior arrangement.

Exclusions for documentation and product usage

UNLESS SPECIFICALLY AGREED TO IN WRITING, SAMLEX EUROPE B.V. ("SAMLEX") :

1. MAKES NO WARRANTY AS TO THE ACCURACY, SUFFICIENCY OR SUITABILITY OF ANY TECHNICAL OR OTHER INFORMATION PROVIDED IN ITS MANUALS OR OTHER DOCUMENTATION
2. ASSUMES NO RESPONSIBILITY OR LIABILITY FOR LOSSES, DAMAGES, COSTS OR EXPENSES, WHETHER SPECIAL, DIRECT, INDIRECT, CONSEQUENTIAL OR INCIDENTAL, WHICH MIGHT ARISE OUT OF THE USE OF SUCH INFORMATION. THE USE OF ANY SUCH INFORMATION WILL BE ENTIRELY AT THE USER'S RISK
3. REMINDS YOU THAT IF THIS MANUAL IS IN ANY LANGUAGE OTHER THAN ENGLISH OR DUTCH, ALTHOUGH STEPS HAVE BEEN TAKEN TO MAINTAIN THE ACCURACY OF THE TRANSLATION, THE ACCURACY CANNOT BE GUARANTEED.
4. MAKES NO WARRANTY, EITHER EXPRESSED OR IMPLIED, INCLUDING BUT NOT LIMITED TO ANY IMPLIED WARRANTIES OF MERCHANTABILITY OR FITNESS FOR A PARTICULAR PURPOSE, REGARDING THESE SAMLEX PRODUCTS AND MAKES SUCH SAMLEX PRODUCTS AVAILABLE SOLELY ON AN "AS IS" BASIS.
5. SHALL IN NO EVENT BE LIABLE TO ANYONE FOR SPECIAL, COLLATERAL, INCIDENTAL, OR CONSEQUENTIAL DAMAGES IN CONNECTION WITH OR ARISING OUT OF PURCHASE OR USE OF THESE SAMLEX PRODUCTS. THE SOLE AND EXCLUSIVE LIABILITY TO SAMLEX, REGARDLESS OF THE FORM OF ACTION, SHALL NOT EXCEED THE PURCHASE PRICE OF THE SAMLEX PRODUCTS DESCRIBED HERE IN.

Document name, date and part number

"Powersine 200-800 Manual Rev5endfs", April 2015, 201483

TABLE OF CONTENTS

1. INTRODUCTION.....	5
2. INSTALLATION.....	5
2.1 Placement of the inverter.....	5
2.2 The “Remote on/off” function (PS600-12 up to PS800-48 models only).....	6
2.3 Battery requirements.....	7
2.4 Connection to the battery.....	8
2.4.1 General precautions about working with batteries.....	8
2.5 Connecting the load.....	9
2.6 Activating the inverter.....	9
3. TROUBLESHOOTING.....	10
3.1 The flash sequence table.....	10/11
3.2 Acoustical messages.....	11
3.3 Troubleshooting guideline.....	12/13
4. WARRANTY / LIMITS OF RESPONSIBILITY.....	14
5. TECHNICAL DATA.....	15
5.1 Powersine 300-12, 350-24 and 450-48.....	15
5.3 Powersine 600-12, 800-24 and 800-48.....	16
6. DECLARATION OF CONFORMITY.....	17

1. INTRODUCTION

Thank you for choosing a Powersine DC to AC inverter as your power source. The Powersine inverter series are one of the most sophisticated inverters available today. With high reliability, efficiency and sine quality as our most important design goals, the Powersine inverter series is developed to serve you with safe and trouble free operation for years.

Your Powersine inverter features an advanced micro processor control system with a MOSFET power stage and a low loss toroidal transformer. This toroidal transformer in combination with well over dimensioned power components, ensures a very reliable operation, so that extreme overload conditions, like startup of compressors or pumps, can be handled safely.

To get optimal feedback from your inverter while operating, a build in diagnosis system will warn you optically by different flash sequences, depending on the error situation. See the troubleshooting chapter for the flash sequence table. Also, the inverter will warn you acoustically before it's going to shut down in a low battery, overload or high temperature condition.

To get optimal performance and safe operation from your inverter, it must be installed and used properly. Please read this manual very carefully, especially the warning and caution statements, before installing and using your Powersine inverter.

2. INSTALLATION

2.1 Placement of the inverter

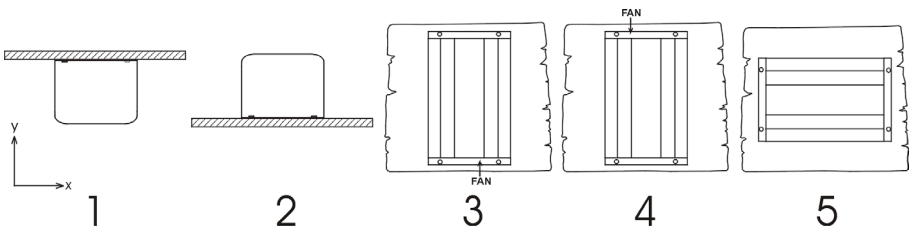

- | | |
|--|--|
| 1. Ceiling mounting | : Not recommended |
| 2. Floor mounting | : OK |
| 3. Vertical wall mounting, fan at bottom | : OK (beware of small objects falling through the ventilation openings on top) |
| 4. Vertical wall mounting, fan on top | : Not recommended |
| 5. Horizontal wall mounting | : OK |

For best operating results, the inverter should be placed on a flat surface. To ensure a trouble free operation of the inverter, it must be used in locations that meet the

following requirements :

- a. Avoid any contact with water on the inverter. Do not expose the inverter to rain or moisture.
- b. Do not place the unit in direct sunlight or other high temperature environments. Ambient air temperature should be between 0 °C and 50 °C (humidity < 95% non condensing). Note that in some extreme situations the inverter's case temperature can exceed 70 °C.
- c. Do not obstruct the airflow around the inverter. Leave at least 10 centimeters clearance around the inverter. Do not place items on or over the inverter while it's operating. When the inverter is running to hot, it will shut down until a safe temperature level is reached to restart the inverter.
- d. Never use the inverter at locations where there is gas or explosion danger, like for example directly on top of batteries.
- e. Do not expose the inverter to dusty environments

2.2 The “Remote on/off” function (PS600-12 up to PS800-48 models only)

The Powersine 600-12 up to 800-48 models are equipped with “Remote on/off” terminals for connection to an external on/off switch. The two wires of the external switch must be connected to these terminals as indicated below. The slide switch on the frontpanel must be moved to the right (factory setting is left) when operating the unit by a remote switch as shown below :

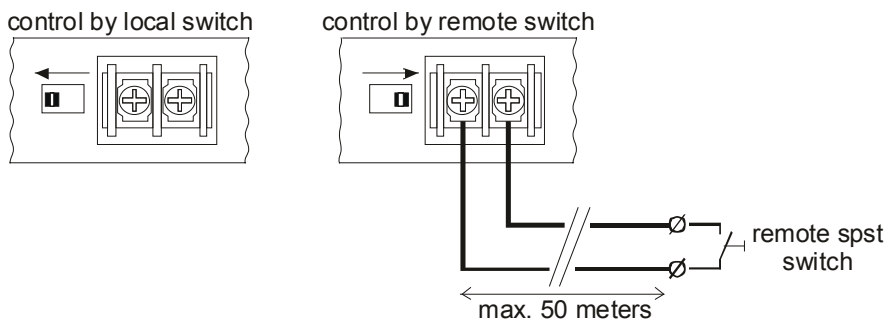

The local on/off switch on the frontpanel always overrides the remote switch. So in order to use the remote switch, the local on/off switch must be in the 'on' or 'auto standby' (ASB) position.

 CAUTION	<p>MAKE SURE THAT WHEN INSTALLING THE REMOTE SWITCH, THE BATTERY IS NOT CONNECTED YET.</p>
--	---

2.3 Battery requirements

For correct operation, the battery voltage should be between $0.92 \times V_{nom}$ and $1.23 \times V_{nom}$ where V_{nom} is 12V, 24V or 48V depending on model, and must be able to supply sufficient current to your inverter. The following table displays the recommended battery capacity per inverter type :

Inverter type :	Iin at Pnom :	Recommended battery cap. :
PS300-12	26 ADC	≥ 100 Ah
PS350-24	15 ADC	≥ 60 Ah
PS450-48	7 ADC	≥ 30 Ah
PS600-12	47 ADC	≥ 200 Ah
PS800-24	29 ADC	≥ 120 Ah
PS800-48	14 ADC	≥ 60 Ah

For short time inverter usage the recommended battery capacity can be halved. The inverter shuts down when the battery voltage is below approx. $0.88 \times V_{nom}$ or above $1.3 \times V_{nom}$. In a low or high battery situation the inverter is generating one beep per second to inform you about a possible inverter shut down (except PS200-xx models). This acoustical message will start at a battery voltage which is close to the shutdown voltage.

 CAUTION	<p>ALL 12V INVERTERS MUST BE CONNECTED ONLY TO A 12V BATTERY. The inverter will not operate from a 6V battery and will be damaged when connected to battery voltages higher than 24V.</p> <p>ALL 24V INVERTERS MUST BE CONNECTED ONLY TO A 24V BATTERY. The inverter will not operate from a 12V battery and may be damaged when connected to battery voltages higher than 31V.</p> <p>ALL 48V INVERTERS MUST BE CONNECTED ONLY TO A 48V BATTERY. The inverter will not operate from a $< 40V$ battery and may be damaged when connected to battery voltages higher than 60V.</p>
--	---

2.4 Connection to the battery

Unless it is absolutely necessary, SAMLEX advises not to extend the battery wires. Extending the battery wires may increase system losses and can cause inverter malfunctioning. If it is unavoidable to extend these wires, use a wire gauge of at least 1.5 times larger than the ones supplied with the inverter. Maximum recommended battery wire length is approx. 3 meters.

2.4.1 General precautions about working with batteries

1. Working in vicinity of a lead acid battery is dangerous. Batteries can generate explosive gases during operation. Never smoke or allow a spark or flame in vicinity of a battery. Provide sufficient ventilation around the battery.
2. Wear eye and clothing protection. Avoid touching eyes while working near batteries. Wash your hands when done.
3. If battery acid contacts skin or clothing, wash immediately with soap and water. If acid enters eye, immediately flood eye with running cold water for at least 15 minutes and get medical attention immediately.
4. Be careful when using metal tools in vicinity of batteries. Dropping a metal tool onto a battery might cause a shorted battery and an explosion.
5. Remove personal metal items such as rings, bracelets, necklaces, and watches when working with a battery. A battery can produce a short-circuit current high enough to weld a ring or the like to metal, causing severe burns.

 <p>CAUTION</p>	<p>THE RED WIRE MUST BE CONNECTED TO THE POSITIVE (+) TERMINAL AND THE BLACK WIRE TO THE NEGATIVE (-) TERMINAL OF THE BATTERY.</p> <p>Reverse polarity connection of the battery wires can damage the inverter! Damage caused by reversed polarity is <u>not</u> covered by the warranty. Make sure the power switch is in the OFF '0' position before connecting the battery.</p>
--	---

2.5 Connecting the load

Before you connect your appliance(s) to the inverter, always check its maximum power consumption. Do not connect appliances to the inverter needing more than the nominal power rating of the inverter continuously. Some appliances like motors or pumps, are drawing large inrush currents in a startup situation. In these situations, it is possible that the startup current exceeds the overcurrent trip level of the inverter. In this case the output voltage will shortly decrease to limit the output current of the inverter. If this overcurrent trip level is continuously exceeded, the inverter will shut down and restart within 18 seconds. In this case it is advisable to disconnect this appliance from the inverter, since it requires too much power to be driven by this inverter. Note that at higher ambient temperature levels, the overload capacity of the inverter is reduced.

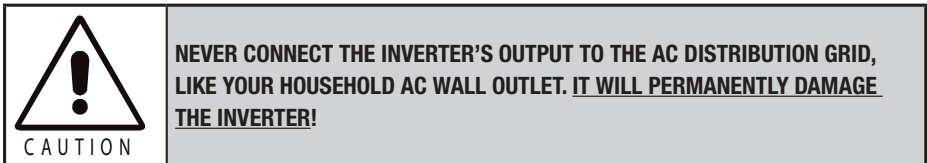

2.6 Activating the inverter

When all the above requirements are checked and satisfied and all connections are made, it's time to turn on your Powersine inverter by pushing the power switch in the 'I' position (see top label for push direction). After a short two tone beep, indicating that all internal circuits are checked, the sinewave shaped output voltage is gently rising until $230V/50Hz \pm 2\%$ (or $115V/60Hz \pm 3\%$) is reached.

When the inverter is not supplying power to an appliance for a longer time, it's recommended to use the inverter in the "Auto Standby" (ASB) mode to heavily reduce the inverter's own power consumption. In this case the power switch must be pushed in the 'II' position. In the ASB mode the inverter will generate a testpulse on its output once per second, to check if there is a load applied. When the ASB mode is activated (by generating a reversed two tone beep, the indicator LED will be continuously on for 4 seconds while the inverter outputs a continuous 230V (or 115V) sinewave. After this 4 seconds the continuous output will change to a pulsed output, indicated by a flashing indicator LED. When a load is connected to the inverter output (or switched on) drawing more than approx. 5W, 12W or 15W (depending on model), the inverter jumps to the continuous mode immediately, delivering power to the load. When the load is disconnected again (or switched off), the indicator LED starts flashing again after 4 seconds, and the inverter jumps back to the pulsed output ASB mode. This way the inverter automatically jumps to a low power 'sleep' mode when there is no power demand on the output.

Note that some loads like TV/video equipment (with standby mode) and alarm clocks need continuous power so that the ASB mode can not be used. With some small non compensated loads, it is possible that the inverter jumps from continuous output to

pulsed output and vice versa all the time. In this case you have to connect a small additional load to the AC output

 <p>WARNING</p>	<p>IF THE INVERTER JUMPED INTO AN 'ERROR MODE' (SEE CHAPTER 3.1) DUE TO AN OVERLOAD OR SHORT CIRCUIT, THE INVERTER WILL AUTOMATICALLY RE-START AFTER ABOUT 18 SECONDS.</p> <p>In case of an over temperature error, the inverter will automatically restart after it has reached an acceptable temperature. Right before the inverter will restart, it will warn you with a short two-tone beep.</p> <p>NEVER SERVICE THE AC CONNECTIONS WHEN THE INVERTER IS STILL RUNNING IN AN ERROR MODE!</p>
--	---

 <p>WARNING</p>	<p>THE BUILD IN LARGE ELECTROLYTIC CAPACITORS CAN HOLD SIGNIFICANT DC VOLTAGE WHEN THE BATTERIES ARE DISCONNECTED.</p> <p>To avoid sparks or short inverter operation, it is advisable to switch on the inverter for 10 seconds after battery disconnection, before you transport the inverter.</p>
--	--

3. TROUBLESHOOTING

3.1 The flash sequence table

Your Powersine inverter is equipped with a self diagnosis system, to inform you about the cause of inverter shut down. To make this visible the red error/power LED on the front panel of the inverter, can flash in four different sequences. The duration, or time period, of this sequence is about 1 second. During this time period the red LED can flash four times in a row at most. The number of flashes in this time period indicates the cause of inverter shut down.

In the next table you can find out what kind of flash sequence belongs to which error.

Red LED conditions :	
●	= LED flashing
●	= LED ON
○	= LED OFF
Time period (1 second)	Type of error
●○○○	Battery voltage too low, too high (one flash per second)
●●○○	Overloaded or shorted output (two flashes per second)
●●●○	Inverter temperature too high. Cooling down (three flashes per second)
●●●●	Inverter in ASB mode (four flashes per second)
● —> Power ON, inverter in normal operation	
○ —> Inverter OFF	

3.2 Acoustical messages

To warn you before the inverter might shut down, the inverter is equipped with an acoustical alarm. There are three kinds of acoustical messages depending on the cause of possible inverter shutdown. These messages are related to the red LED blinking sequences mentioned previously.

Message 1: **One beep per second.** The battery voltage has reached a too low or too high level. If the battery voltage respectively decreases or increases any further, the inverter shuts down.

Message 2: **Two beeps per second.** The inverter will shut down soon due to an overloaded output. Note that at heavy overloads the alarm will not sound due to too fast inverter shut down.

Message 3: **Three beeps per second.** The inverter will shut down when its temperature is rising another three degrees Celsius.

3.3 Troubleshooting guideline

PROBLEM : Inverter is not working (red LED OFF)	
Possible cause :	Remedy :
Power switch in OFF (0) position	Push the power switch in the ON (1) position.
Poor contact between the inverter's battery wires and the battery terminals.	Clean battery terminals or inverter wire contacts. Tighten battery terminal screws.
Blown inverter fuse	The inverter has to be returned for service.
Very poor battery condition	Replace battery

PROBLEM : 'Battery voltage too low or too high' error keeps on appearing	
Possible cause :	Remedy :
Poor battery condition	Replace battery or charge it first
Poor connection or inadequate wiring between battery and inverter, resulting in too much voltage drop	When extending the battery wires of the inverter make sure you use the correct wire gauge (≥ 1.5 times larger than the fixed battery wires). It's not advisable to extend the battery wires to more than 3 meters.
General failure in your electrical system (in case of no direct battery connection)	Check your electrical system or consult an electrical engineer to check it for you

PROBLEM : 'Overloaded or shorted output' error keeps on appearing	
Possible cause :	Remedy :
Inverter is overloaded	Make sure that the total power rating of the connected equipment is lower than the nominal inverter power rating.
Connected equipment features a bad power factor (cos ϕ) at sinusoidal currents)	reduce the required power consumption of the load. Please note that for example most computer loads feature a bad power factor, which causes a reduction of the maximum output power of the inverter by approx. 20%.
Connected equipment causes a short circuit at the inverter's output	Make sure that the connected equipment is not broken or malfunctioning. Check if the AC power cord between the inverter and the connected equipment is ok. Any physical damage on the power cord can produce a short circuit. Be careful in these kind of situations!

Connected equipment produces a too large inrush current	Try to power-up connected equipment successively, and not simultaneously. Or connect the load first and then turn-on the inverter. Otherwise stop using the connected load, it's not suitable to drive it with this inverter
---	--

PROBLEM : 'Inverter temperature too high. Cooling down' error keeps on appearing	
Possible cause :	Remedy :
Airflow around the inverter is obstructed	Make sure there is at least 10 centimeters of clearance around the inverter. Remove any items placed on or over the inverter. Keep the inverter away from direct sunlight or heat producing equipment
Too high ambient temperature	Move the inverter to a cooler place or provide additional cooling by an external fan

Note : Don't turn off the inverter when it's operating in an 'Inverter temperature too high. Cooling down' error. The inverter needs this error time to cool down.

PROBLEM : Inverter jumps between continuous mode and ASB mode all the time	
Possible cause :	Remedy
Connected load is not compensated or the ratio between inrush current and continuous current is too large.	Connect an additional load to the output.

If none of the above remedies will help solving the problem you encounter, it's best to contact your local Samlex distributor for further help and/or possible repair of your inverter. Do not open the inverter yourself, there are dangerous high voltages present inside. Opening the inverter will directly void your warranty.

4. WARRANTY / LIMITS OF RESPONSIBILITY

SAMLEX EUROPE B.V. (SAMLEX) warrants this inverter to be free from defects in workmanship or materials for 24 months from the date of purchase. During this period SAMLEX will repair the defective inverter free of charge. SAMLEX is not responsible for any costs of the transport of this inverter.

This warranty is void if the inverter has suffered any physical damage or alteration, either internally or externally, and does not cover damage arising from improper use¹⁾, attempting to operate the inverter with excessive power consumption requirements, or from use in an unsuitable environment.

This warranty will not apply where the product has been misused, neglected, improperly installed or repaired by anyone other than SAMLEX. SAMLEX is not responsible for any loss, damage or costs arising from improper use, use in an unsuitable environment, improper installing of the inverter and inverter malfunctioning.

Since SAMLEX cannot control the use and installation (according to local regulations) of their products, the customer is always responsible for the actual use of these products. SAMLEX products are not designed for use as critical components in life support devices or systems, that can potentially harm humans and/or the environment. The customer is always responsible when implementing SAMLEX products in these kind of applications. SAMLEX does not accept any responsibility for any violation of patents or other rights of third parties, resulting from the use of the SAMLEX product. SAMLEX keeps the right to change product specifications without previous notice.

¹⁾ Examples of improper use are :

- Too high input voltage applied
- Reverse connection of battery polarity
- Mechanical stressed enclosure or internals due to harsh handling and/or incorrect packaging
- Backfeed via inverter output from external power source like public grid or generator
- contact with any liquids or oxidation caused by condensation

5. TECHNICAL DATA

5.1 Powersine 300-12, 350-24 and 450-48

TECHNICAL DATA			
	PS300-12	PS350-24	PS450-48
Output power ¹⁾ : @ Ta = 25°C			
Pnom	250W	300W	300W
P10minutes	330W	360W	450W
Psurge	700W	800W	800W
Output voltage	230Vac ± 2% (115vac ± 2% optional)		
Output frequency	50Hz ± 0.05% (60Hz ± 0.05% optional)		
Output waveform	True sinewave (THD < 5% ¹⁾ @ Pnom)		
Permissible cos j of load	0.2 – 1 (up to Pnom)		
Input voltage (± 3% tolerance) :			
Nominal	12Vdc	24Vdc	48Vdc
Range	10.5 ²⁾ – 16Vdc	21 ²⁾ – 31Vdc	41 ²⁾ – 60Vdc
Maximum efficiency	91%	93%	95%
No load power consumption at nominal input voltage [ASB]	< 3W [0.7W]	< 3.5W [0.8W]	< 6.5W [1.3W]
Operating temperature range (ambient)	-20°C to +50 °C		
ASB threshold	Pout = 12W	Pout = 15W	Pout = 15W
Protections against	Short circuit, overload, high temperature and low battery voltage		
Indications (by flashing sequences of the power LED)	Power on, short circuit/overload, high temperature, high/low battery voltage and ASB mode		
DC input connection	Two wires, length 1.5 meters, Ø 4mm ²		
AC output connection	Schuko AC outlet (Standard)		
Enclosure body size (l x h x w)	184 x 98 x 130mm (without mounting brackets)		
Protection class	IP20		
Total weight	3.5 kg	3.5 kg	3.5 kg
The inverter complies with the following standards :	See page 17		

5.2 Powersine 600-12, 800-24 and 800-48

TECHNICAL DATA			
	PS600-12	PS800-24	PS800-48
Output power ¹⁾ : @ Ta = 25°C			
Pnom	500W	600W	600W
10minutes	600W	800W	800W
surge	1000W	1200W	1250W
Output voltage	230Vac ± 2% (115Vac ± 2% optional)		
Output frequency	50Hz ± 0.05% (60Hz ± 0.05% optional)		
Output waveform	True sinewave (THD < 5% ¹⁾ @ Pnom)		
Permissible cos j of load	0.2 – 1 (up to Pnom)		
Input voltage (± 3% tolerance) :			
Nominal	12Vdc	24Vdc	48Vdc
Range	10.5 ²⁾ – 16Vdc	21 ²⁾ – 31Vdc	41 ²⁾ – 60Vdc
Maximum efficiency	92%	93%	94%
No load power consumption at nominal input voltage [ASB]	< 4.8W [0.4W]	< 6.5W [0.7W]	< 8.2W [0.5W]
Operating temperature range (ambient)	-20°C to +50 °C		
ASB threshold	Pout = 15W	Pout = 15W	Pout = 15W
Protections against	Short circuit, overload, high temperature and low battery voltage		
Indications (by flashing sequences of the power LED)	Power on, short circuit/overload, high temperature, high/low battery voltage and ASB mode		
DC input connection	Two wires, length 1.5 meters, Ø 10mm ²		
AC output connection	Schuko AC outlet (Standard)		
Enclosure body size (l x h x w)	228 x 113 x 163mm (without mounting brackets)		
Protection class	IP20		
Total weight	6.2 kg	6.2 kg	6.2 kg
The inverter complies with the following standards :	See page 17		

¹⁾ Measured with resistive load. Power ratings are subject to a tolerance of ± 4% and are decreasing as temperature rises with a rate of approx. 1.2%/°C starting from 25°C.

²⁾ Undervoltage limit is dynamic. This limit decreases with increasing load to compensate the voltage drop across cables and connections.

6. DECLARATION OF CONFORMITY



IMPORTER : SAMLEX EUROPE B.V.
ADDRESS : ARIS VAN BROEKWEG 15
1507 BA ZAANDAM
The Netherlands

Declares that the following products :

PRODUCT TYPE : DC TO AC SINEWAVE INVERTER
MODELS : - Powersine 300-12
- Powersine 350-24
- Powersine 450-48
- Powersine 600-12
- Powersine 800-24
- Powersine 800-48

Conform to the requirements of the following Directives of the European Union :

EMC Directive 2004/108/EC
Automotive Directive 95/54/EC

The above products are in conformity with the following harmonized standards :

Low Voltage Directive 2006/95/EC
EN61000-6-3 : 2001 EMC - Generic Emissions Standard
EN61000-6-2 : 2005 EMC - Generic Immunity Standard
EN60335-1 : 2004 Generic safety standard

A handwritten signature in blue ink, appearing to read 'M. van Veen', is written over a faint dotted line.

Marcel van Veen
Managing Director

Date: 01-05-2015



www.samlex.com
www.samlex-solar.com